

# Design and Fabrication of Motorized Hydraulically Operated Palm Oil Press.

P.A. Azodo, M.Eng.<sup>1\*</sup>; A.B. Hassan, Ph.D.<sup>2</sup>; J. Ezenwa, B.Eng.<sup>2</sup>; and P.U. Ogban, B.Eng.<sup>3</sup>

<sup>1</sup>Mechanical Engineering Department, Federal University of Agriculture, PMB 2240, Abeokuta, Nigeria.

<sup>2</sup>Mechanical Engineering Department, Federal University of Technology, PMB 65, Minna, Nigeria.

<sup>3</sup>Mechanical Engineering Department, Federal University, PMB 146, Lafia, Nigeria.

E-mail: [azodopat@gmail.com](mailto:azodopat@gmail.com)\*

## ABSTRACT

A motorized hydraulically operated palm oil press was designed, constructed, and tested. The basic features of the palm oil press are the frame, hydraulic ram, hydraulic pump, a 2-way valve, electric motor, cage, collector, sprout, pressing plate, pressure hoses, and hydraulic tank. This machine was aimed at easing the pain, stress, intensive labor, and time consumption encountered in the existing palm oil pressing processes. The machine has a capacity of 330.96 KN/m<sup>2</sup>. Average pressing time of 4.35 minutes was achieved for three palm oil pressing test carried out. The hydraulic pressure extracted oil from the digested fruit with less labor or drudgery.

(Keywords: palm oil, palm fruit, hydraulic, press, capacity, design, testing)

## INTRODUCTION

Oil palm (*Elaeis guineensis*) is a perennial plant generally agreed to originate in the tropical forest of West Africa (FAO 2004). It is a single, indispensable tree with many vital by-products. The products include palm oil, palm kernel oil, palm kernel cake, fiber, palm wine, fatty alcohol, broom, and wood plank. Many have called it the richest productive plant in the plant kingdom (Kheiri 1985, Kurki et al., 2008). The oil palm gives the highest yield of oil per unit area compared to any other crop and produces two distinct oils - palm oil and palm kernel oil - both of which are important in world trade (FAO, 2004).

The importance of oil palm produce to man cannot be overemphasized. Most nations of the world are involved in palm oil production. Africa led the world in production and export of palm oil throughout the first half of the 20<sup>th</sup> century, led by Nigeria and Zaire (now called Democratic

Republic of the Congo). Malaysia and Indonesia surpassed Africa's total palm oil production by 1966. According to Oil Palm Review, published by the Tropical Development and Research Institute in the United Kingdom, over 3 million tonnes of palm oil was produced by Malaysia alone in 1983, compared with a total of about 1.3 million tonnes of African production (FAO, 2004). In 2008, Malaysia produced 17.7 million tonnes of palm oil on 4,500,000 hectares (17,000 sq mi) of land and was the second largest producer of palm oil. As of 2009, Indonesia was the largest producer of palm oil producing more than 20.9 million tonnes.

The bulk of oil production is provided by Indonesia and Malaysia as both 44 and 41.5 % respectively, to the world palm oil production (FAO, 2004). As of 2011, Nigeria was the third-largest producer and West Africa's largest producer, with more than 2.5 million hectares (6.2×10<sup>6</sup> acres) under cultivation. Until 1934, Nigeria had been the world's largest producer. Historically, oil palm has played an important part in the Nigerian economy.

In 1900, when the total agricultural commodities amounted to 95.6% of total exports, the contribution made by palm oil and palm-kernel alone was 81.6% or \$2,242,000. This continued to be the pattern of export trade until the mid—1920s when increasing contributions were made by cocoa and groundnuts (Jekayinfa and Bamgboye, 2006).

During the period 1959 –1965, commercial exports of palm oil and palm-kernels averaged 163,000 and 414,000 ton per annum, respectively. Export of palm produce from Nigeria, therefore, constituted nearly 30% (palm oil) and 50% (palm-kernel) of the world trade in these commodities. The production of palm oil in Nigeria reached its lowest ebb during the

Nigerian civil war (1966–1970). It was estimated in 1978 that Nigeria became a net importer of palm oil with 3000 tons worth \$16 million (Jekayinfa and Bamgboye, 2006). Though, latter in 1987, her exports increased to about 6.5 million tones, which earned her the third largest exporter of oil that year (Omuta and Onorkahrage, 1997). This was possible because the Federal Government of Nigeria introduced the Structural Adjustment Programme (SAP) which led to the prohibition of importation of some essential products (including soap, cooking oil and body/hair cream) as policy measures to revive the economy, minimize the dependence on importation and to build a non-oil export based economy (Aina, 2002).

These policy measures rekindled an interest in agriculture on the part of many Nigerians and Nigerian organizations. The government through different agencies likes Agricultural Development Projects (ADPs), Directorate of Foods, Road and Rural Infrastructure (DFFRI) and Federal Institute of Industrial Research Oshodi (FIRO) made efforts to increase local production of these essential commodities through incentives given to farmers and organizations (Aina, 2002; Jekayinfa, 2004; Olajide & Oyelade, 2002). To effectively revitalize Nigeria palm oil processing sector, there is need to improve the design of the palm oil machine, the palm oil extractor, for productivity, efficiency, ergonomics and safety of handling the machine. Through this cost effectiveness, conducive and environmentally friendly operating conditions will be achieved.

## **PALM OIL EXTRACTION METHODS**

Various techniques may be used to process palm oil fruits for edible oil. The extraction of palm oil is done using either the traditional methods or through the use of machines which can either be manually or mechanically operated.

### **THE TRADITIONAL METHOD OF OIL EXTRACTION**

The traditional method of palm oil extraction started before the advent of machinery. This is a crude means that gives a product poor quality. The traditional method of oil extraction consists of steeping the pounded fruit mash in hot or cold water; removing fiber and nuts in small baskets and hand squeezing; filtering out residual fiber

from the oil/water emulsion in perforated metal colanders or baskets; boiling and skimming palm oil from the oil/water mixture; drying the recovered oil. Standing by the open fire during this operating period is not only a health hazard but is inefficient, as a lot of oil is left trapped in the mixture as an emulsion. In the traditional method, two major types of oil are produced: Soft oil and the hard oil (Asiedu, 1989).

## **MECHANICAL METHODS OF EXTRACTION OF PALM OIL**

Within increasing demand for palm oil from the west coast of Africa; it was clear even by the turn of the century that tradition methods of extraction could not satisfy either demand or quality requirements and that they gave a very meager return to the producer. Consideration was therefore given to providing oil extraction methods, which could be easily adopted by the small or large producer (Asiedu, 1989).

## **MATERIALS AND METHODS**

### **Parts of the Palm Oil Press**

The palm oil press is made up of the following units: the frame, hydraulic ram, hydraulic pump, a 2-way valve, electric motor, cage, collector, sprout, pressing plate, and hydraulic tank (Figure 1).

### **Design and Construction**

The constructional detail of each of the separate components that make up the press is discussed below;

**Frame:** Weight of the electric motor, the valve, the hydraulic pump, the hydraulic ram and its supports, hydraulic tank were considered in designing the frame. U-channel mild steel was used for the frame for strength and rigidity due to load of component parts and pressing pressure. The frame is of triangular shape. Sub-supports like that for electric motor, ram and hydraulic tank were welded to the main frame to provide support for the various components. 1.5 inch angle bar of thickness 3 mm used to fabricate rectangular seats for the electric motor and the hydraulic tank. Two cylindrical pipes of 460mm length, 60 mm diameter and 4mm thickness were used to support the ram.

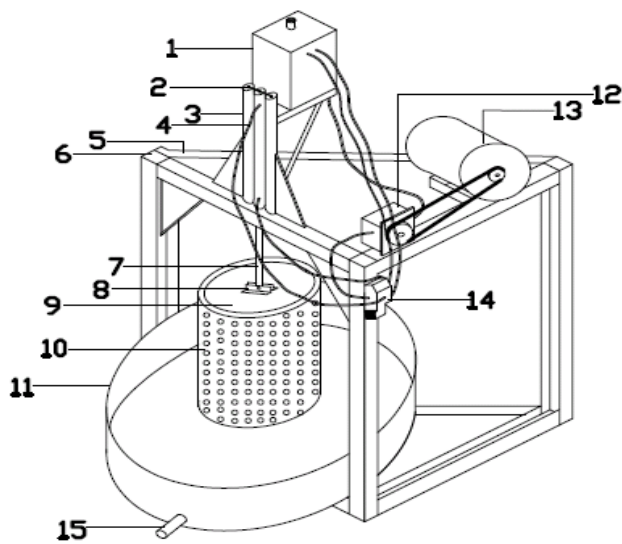
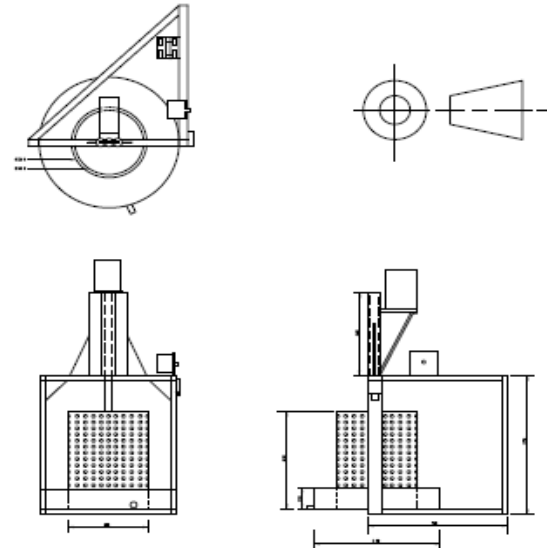

**Figure 1:** Diagram of the Motorized Hydraulically Operated Palm Oil Press.

**Table 1:** Parts of Motorized Hydraulically Operated Palm Oil Press.

| S/N | PARTS                  |
|-----|------------------------|
| 1   | Hydraulic tank         |
| 2   | Hydraulic tank support |
| 3   | Ram support            |
| 4   | Pressure hose          |
| 5   | Angle bar              |
| 6   | Frame                  |
| 7   | Ram rod (piston)       |
| 8   | Piston palisade        |
| 9   | Pressing plate         |
| 10  | Cage                   |
| 11  | Collector              |
| 12  | Hydraulic pump         |
| 13  | Electric motor         |
| 14  | 2-way valve            |
| 15  | Spout                  |

**Collector:** The collector is a cylinder of diameter 660 mm, height 130 mm and thickness 5 mm with one end closed for collecting the oil from the cage during pressing.



**Figure 2:** Orthographic Drawing of the Motorized Hydraulically Operated Palm Oil Press.

**Spout:** This was cut from a galvanized pipe of diameter and thickness 40 and 2 mm respectively. This was connected to the opening in the collector by welding.

**Cage:** This was made from sheet metal of thickness of 5 mm. Thickness of 5 mm was used to withstand the internal pressure that is built up due to the pressing pressure. The extraction cuts on the cage were perforated round staggered of diameter of 5 mm throughout the circumference of the cage. It was made of two halves, joined with hinges. It has two handles welded to the side for lifting the cage after the pressing operation. The diameter of the press cage is 400 mm

**Pressing Plates:** The pressing plate is a steady steel disc of 8 mm thickness. Cut to circular shape of diameter 380 mm. welded to the center is a nut for attachment to the ram.

**Lock pins:** These were made from mild steel rod of diameter 10mm. They were made in form of a "Tee" shape by welding. These are locks for the cage before loading the digested palm pulp into cage for pressing.

**Hydraulic Tank:** 2 mm thick mild steel sheet was used for the hydraulic tank of size 200 x 160 x 300 mm. A neck was welded to the top, through which the hydraulic fluid can be poured into the tank. An outlet pipe of 20 mm in diameter was welded to the bottom to serve as inlet to the

pump. Also a diameter 17 mm bolt and nut was weld to the bottom for draining should the tank needed to be dismantled.

**Connecting Hoses:** The connecting hoses are pressure hoses in order to withstand the pump pressure and ram pressure.

**2-way Valve:** The valve required in order for the machine to perform effectively is a two way valve. This is to enable the fluid to move to the upper and lower chamber of the ram. The 2-way valve pumps the hydraulic oil to and from the hydraulic tank. It also controls the flow of the fluid pressure. The valve controls the down movement of the ram during pressing operation and up movement after the pressing operation. It is controlled by the lever of the control valve

**Hydraulic Pump:** Hydraulic pumps are positive displacement pumps that pumps fluid to create a non-pulsating pumping action. Hydraulic pumps are able to pump at high pressures and excel at pumping high viscosity liquids efficiently. The pump capacity is 1.8 kW. Pump pulley diameter is 125 mm. The hydraulic ram is controlled by a hydraulic pump.

**Electric Motor:** Electric motor is the one of common device for rotating equipment and it is useful for smooth operation and makes our process faster and more efficient. 5 Hp motor capacity and Speed of 1750 rpm was considered proper and suitable for the load, speed and the whole system. Motor pulley diameter is 70 mm

**Hydraulic Ram:** A 30psi (206.85KN/m<sup>2</sup>) capacity hydraulic ram was used for the palm oil press. The diameter of the ram is 250mm.

**DESIGN CALCULATIONS**

**Determination of Hydraulic Pressure of the Palm Oil Press:** The diameter of the ram is given as 250 mm. The diameter of the press cage is 400 mm; hence in order to produce the required pressure on the fruit, the hydraulic pressure (P<sub>h</sub>) must be:

$$P_h = \text{pressure of the ram} \times \frac{(\text{diameter of cage})^2}{(\text{diameter of ram})^2}$$

(Asiedu, 1989)

$$P_h = 206.85 \times \frac{400}{250}$$

$$= \frac{82740}{250} = 330.96 \text{ KN/m}^2$$

**The Power Drive Mechanism**

Proper calculation was done to avoid overload, and motor burn due to wrong estimation about load. The power transmission of the machine is by pulley and belt arrangement as shown in Figure 1. The speed of the pump depends on:

- i. The speed of the electric motor.
- ii. The diameter of the pulleys.

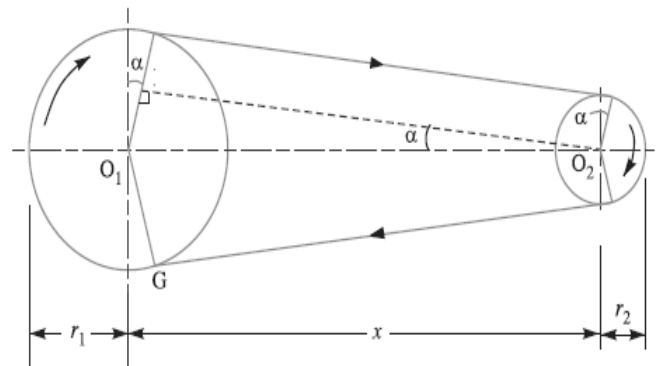

**Figure 2:** Arrangement of the pulleys. (Source: Khurmi and Gupta 2006)

The selected motor of 5 hp delivers at speed of 1750 rpm which was connected to the hydraulic pump pulleys. A diameter of the motor shaft pulley of 70mm was selected. The pump speed N<sub>p</sub>, was calculated as follows:

$$\frac{\text{speed of driven } (N_p)}{\text{speed of driver } (N_m)} = \frac{\text{diameter of driver } (D_m)}{\text{diameter of driven } (D_p)}$$

$$N_p = \frac{N_m \times D_m}{D_p} \quad (\text{Khurmi and Gupta, 2006})$$

$$N_p = \frac{1750 \times 70}{125}$$

$$N_p = \frac{122500}{125} \quad N_p = 980 \text{ rpm}$$

Where:

$N_m$  = speed of electric motor

$N_p$  = speed of the pump

$D_m$  = diameter of motor pulley

$D_p$  = diameter of pump

### Belt Analysis

**Determination of Center Distance:** The center distance,  $x$ , between two adjacent pulleys was determined using the relation:

$$x = \frac{D_m + D_p}{2} + D_m$$

$$x = \frac{70 + 125}{2} + 70$$

$$x = \frac{195}{2} + 70$$

$$x = 97.5 + 70$$

$$x = 167.5 \text{ mm}$$

**Determination of the Belt Length ( $L_b$ ):**

$$L_b = \frac{\pi}{2}(R + r) + 2x + \frac{(R-r)^2}{4x}$$

or,

$$L_b = \frac{\pi}{2}(d_m + d_p) + 2x + \frac{(d_m + d_p)^2}{4x}$$

(Khurmi and Gupta, 2006)

$$L_b = \frac{3.142}{2} x(125 + 70) + 2 x 168 + \frac{(125 + 70)^2}{4 x 168}$$

$$L_b = \frac{3.142}{2} x(195) + 2 x 168 + \frac{(195)^2}{4 x 168}$$

$$L_b = \frac{612.69}{2} + 336 + \frac{38025}{672}$$

$$L_b = 306.34 + 336 + 56.58$$

$$L_b = 698.94 \text{ mm}$$

Where:

$L_b$  = length of belt

$d_1$  = diameter of motor pulley (smaller pulley)

$d_2$  = diameter of pump pulley (larger pulley)

$x$  = distance between the centres of two pulleys

**Belt Speed:**

$$V = \omega r_m$$

$$\omega = \frac{2\pi N_m}{60} \quad (\text{Khurmi and Gupta, 2006})$$

$$\omega = \frac{2 \times 3.142 \times 1750}{60}$$

$$\omega = \frac{10997}{60}$$

$$\omega = 183.28 \text{ rad/s}$$

but

$$V = \omega r_m$$

$$V = \frac{2\pi r_m N_m}{60}$$

$$V = 183.28 \times 0.035$$

$$V = 6.41 \text{ m/s}$$

Where:

$V$  = Belt speed in m/s

$\omega$  = angular speed of electric motor

$r_m$  = radius of the electric motor pulley

$N_m$  = Speed of electric motor

### Mass per Unit Length of Belt:

$$M = \rho g A \quad (\text{Khurmi and Gupta, 2006})$$

$$\rho = 980 \text{kg/m}^3$$

$$g = 9.81 \text{m/s}^2$$

A = cross-sectional area of the belt

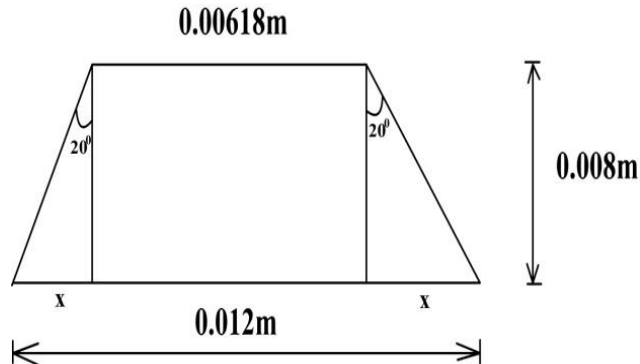

Figure 3: Cross-Sectional Area of the Belt.

$$\tan 20^\circ = x/0.008$$

$$0.008 \tan 20^\circ = x$$

$$x = 0.00291 \text{m}$$

But,

$$A = \frac{1}{2} (0.00618 + 0.012) \times 0.008$$

$$A = 7.272 \times 10^{-5} \text{m}^2$$

Then mass per unit length

$$M = 980 \times 9.81 \times 7.272 \times 10^{-5}$$

$$M = 0.699 \text{kg/m}$$

Where:

$\rho$  = density of belt material

$g$  = acceleration due to gravity  $9.8 \text{m/s}^2$

A = Area of the belt

### Centrifugal Tension of Belt:

$$T_c = MV^2 \quad (\text{Khurmi and Gupta, 2006})$$

$$T_c = 0.699 \times (6.41)^2 = 28.72 \text{ N}$$

Where:

$T_c$  = centrifugal tension of belt

$M$  = mass per unit length of belt in kg/m

$V$  = Belt speed

### Angle of Wrap ( $\theta$ ):

Angle of wrap for electric motor pulley

$$\theta_m = 180 - 2\alpha$$

Angle of wrap for hydraulic pump pulley

$$\theta_p = 180 + 2\alpha$$

We have that:

$$\sin \alpha = \frac{R-r}{x}$$

$$\alpha = \sin^{-1} \frac{R-r}{x}$$

Therefore:

$$\theta_p = 180 + 2\sin^{-1} \frac{R-r}{x}$$

$$\theta_p = 180 + 2\sin^{-1} \frac{62.5 - 35}{168}$$

$$\theta_p = 180 + 2\sin^{-1} 0.1637$$

$$\theta_p = 198.84^\circ$$

$$\theta_p = 198.84^\circ \times \frac{\pi}{180} = 3.47 \text{ rad}$$

$$\theta_m = 180 - 2\sin^{-1} \frac{R-r}{x}$$

$$\theta_m = 180 - 2\sin^{-1} \frac{62.5 - 35}{168}$$

$$\theta_m = 180 - 2\sin^{-1} 0.1637$$

$$\theta_m = 161.16^\circ \times \frac{\pi}{180} = 2.81 \text{ rad}$$

Where:

$\alpha_1$  = angle total

R = radius of hydraulic pump pulley

r = radius of electric motor pulley

x = center distance between the pulleys

(Khurmi and Gupta, 2006)



### Torque Transmitted by Motor ( $T_t$ ):

$$T_t = \frac{\text{Power transmitted by motor (P)}}{\text{Angular speed of motor } (\omega)}$$

$$T_t = \frac{3730}{183.28}$$

$$T_t = 20.35 \text{ N-m}$$

### Torque Exerted on the Driving Pulley Driving Tension on the Driving Belt:

This is given by:

$$\frac{T_1 - T_c}{T_2 - T_c} = e^{\frac{\mu \theta_m}{\sin \frac{\theta}{2}}}$$

(Khurmi and Gupta, 2006)

Where:

$$T_1 = ?,$$

$$T_2 = ?,$$

$$T_c = 28.72 \text{ N},$$

$$\theta = 30^\circ \mu = 0.268$$

$$\theta_m = 2.81 \text{ rad}$$

$$\frac{T_1 - 28.72}{T_2 - 28.72} = e^{\frac{0.268 \times 2.81}{\sin \frac{30}{2}}}$$

$$\frac{T_1 - 28.72}{T_2 - 28.72} = e^{2.91}$$

$$\frac{T_1 - 28.72}{T_2 - 28.72} = 18.36$$

$$T_1 - 28.72 = 18.36 T_2 - 527.30$$

$$T_1 - 18.36 T_2 = -498.58$$

Torque supplied is given by:

$$T_t = (T_1 - T_2)r_1$$

$$20.35 = (T_1 - T_2) \times 0.035$$

$$T_1 - T_2 = 581.43$$

$$T_1 = 581.43 + T_2$$

$$581.43 + T_2 - 18.36 T_2 = -498.58$$

$$17.36 T_2 = 1080.01$$

$$T_2 = 62.21 \text{ N}$$

$$T_1 = 581.43 + 62.21$$

$$T_1 = 643.64 \text{ N}$$

Where:

$T_1$  = tension in the tight side of the belt in Newtons

$T_2$  = Tension in the slack side of the belt in Newtons

$T_c$  = centrifugal tension of belt

$\mu$  = (coefficient of friction between the belt and the pulley)

$\alpha_1$  = angle of wrap of the smaller pulley

$\theta$  = groove angle of the pulley

### Coefficient Friction ( $\mu$ ):

$$\mu = 0.268 \text{ (Khurmi and Gupta, 2006)}$$

Where:

$\mu$  = coefficient of friction between the belt and pulley. This based on the belt material.

### Power Transmitted by Electric Motor:

$$1 \text{ Hp} = 0.746 \text{ kW}$$

$$5 \text{ Hp} = (5 \times 0.746) \text{ kW} = 3.73 \text{ kW}$$

### Power Transmitted by the Belt:

$$P_b = (T_1 - T_2)V \text{ Watts}$$

(Khurmi and Gupta, 2006)

$$P_b = (643.64 - 62.21)6.41$$

$$P_b = 3669.28 \text{ W}$$

Where:

$V$  = Peripheral velocity of the belt in m/s

### Stress Built up in the Cage:

The cylindrical cage is subjected to two types of tensile stresses, viz:

- 1) Circumferential stress
- 2) Longitudinal stress

### Circumferential Stress:

The result of the internal pressure in the cylinder has the tendency to split up the cylinder into two troughs.

Height of the cage H = 650mm

Diameter of the cage D = 400mm

Thickness of the cage t = 10 mm

Total pressure along the diameter of the cage.

We have that stress:

$$\sigma = \text{intensity of stress} \times \text{area} = \sigma dL$$

Circumferential stress in the shell

$$\sigma_c = \frac{\text{Total Pressure}}{\text{Resisting Section}} = \frac{\sigma d l}{2 t l} = \frac{\sigma d}{2 t}$$

(Khurmi, 2008)

$$\text{Hoop stress} = \sigma_h = \frac{\text{Pressure}}{\text{Thickness}} = \frac{P}{t}$$

(Khurmi, 2008)

Where:

$$P = 206.85 \text{KN/m}^2$$
$$t = 5 \text{ mm} = 0.005 \text{ m}$$

$$\sigma_h = \frac{206.85}{0.005} = 41370 \text{KN/m}^2$$

Hoop stress = tensile stress across the diameter:

$$\sigma_c = \frac{\sigma_h d}{2 t} \quad (\text{Khurmi, 2008})$$

$$d = 400 \text{mm} = 0.4 \text{m}$$

$$\sigma_c = \frac{41370 \times 0.4}{2 \times 0.005} = \frac{16548}{0.01} = 165480 \text{KN/m}^2$$

$$\text{Longitudinal stress} = \frac{1}{2} \text{ circumferential stress}$$
$$= \frac{1}{2} \times 165480 = 82740 \text{KN/m}^2$$

### Hydraulic Tank Capacity:

$$V_t = \text{length} \times \text{width} \times \text{height} = L \times W \times H$$

(Ilori et al., 1997)

Where:

$$L = 200 \text{mm} = 0.2 \text{m}$$
$$W = 165 \text{mm} = 0.165 \text{m}$$
$$H = 300 \text{mm} = 0.3 \text{m}$$

$$V_t = 0.2 \times 0.165 \times 0.3 = 0.009 \text{m}^3$$

Where:

$$V_t = \text{volume of tank}$$

### Volume of the Cage:

The Volume of the cage is given by:

$$V_c = \pi r^2 h$$

Where:

$$\text{diameter (d)} = 400 \text{mm}$$
$$r = \frac{d}{2} = 200 \text{mm} = 0.2 \text{m}$$
$$\pi = 3.142$$

$$\text{Height of the cage (h)} = 650 \text{mm} = 0.65 \text{m}$$

$$V_c = 3.142 \times (0.2)^2 \times 0.65 = 0.081692 \text{m}^3$$
$$= 0.082 \text{m}^3$$

### Area of the Pressing Plates

The area of the plate is given by,  $A_p = \pi r^2$

Where:

$$r = d/2$$

The diameter of pressing plate = 390mm,

$$\text{Radius } r = \frac{390}{2} = 195 \text{ mm} = 0.195 \text{ m}$$

$$\text{Area} = 3.142 \times (0.195)^2 = 0.12 \text{ m}^2$$



### Pressure on the Cage:

The force exerted on the cage walls is given:

Force = Ram pressure x Area of pressing plate

The ram pressure =  $206.85 \text{ KN/m}^2$

Force,  $F = \text{Pressure} \times \text{Area}$   
 $= 206.85 \times 0.12 = 24.82 \text{ KN}$   
 $= 24.82 \text{ KN}$ .

### RESULTS AND DISCUSSION

After the palm fruits were digested and separated, the pressing plate was removed and the cage was locked with the "Tee" lock on the circumference of the cage. The hydraulic oil tank was filled to attain the required level to avoid the suction of air. The connections were checked to avoid leakage. This was to avoid loss of pressure that will affect the pressing pressure of the ram piston. The digested pulp is fed into the cage. The pressing plate was replaced. The 5hp electric motor transmits power and rotary movement to the pump pulley, this cause the hydraulic oil from the tank to be sucked via the hose into the pump, the oil passed through the pressure hose into the ram through the valve inlet channel to the upper chamber of the ram thereby building up pressure for pushing down the ram. The ram moved down when the lever on the valve was gently pressed downwards. This requires little or no effort.

After the press is completed the lever is pushed up again to return to its position. This caused the hydraulic oil to enter the ram through the lower nozzle thereby pushing the ram up. This upward movement expels the fluid in the upper chamber of the ram back to the tank. The motorized hydraulically operated palm oil press (Figure 3) was less time consuming and less energy demanding as compared to some of the expeller that is known (manual screw pressure where two or more people will exhaust all their energy in one pressing). Time used in pressing large quantity of digested fruit is reduced compared to other types of palm oil presses encountered. The issue of the strength and capability of the operator required in screw press is sorted out using this palm oil press. The hydraulic pressure extracts oil from the digested fruit with less labor or drudgery. The pressing time was also recorded.

The test was carried out for three different times and average time recorded. The average time of pressing was found to be 4.35 mins. The result of the three presses are tabulated below (Table 2).

**Table 2:** Result of the Three Tests Carried Out Using the Machine.

| Different tests | Time of press (Sec.) |
|-----------------|----------------------|
| First test      | 265                  |
| Second test     | 271                  |
| Third test      | 247                  |



**Figure 3:** Designed and Fabricated Motorized Hydraulically Operated Palm Oil Press with the Designer Beside it.

### CONCLUSION

The design and development of motorized hydraulic operated palm oil press has been reported. The demonstration showed that the equipment performed well in palm oil pressing. The capacity of the machine is  $330.96 \text{ KN/m}^2$ . The time required to completely press the pulp that fill the cage is 4.5mins. The press has been designed generally to meet the need of both local and commercial farmers. Appropriate design consideration and technicalities have been taken into account to ensure the durability of the machine.

## REFERENCES

1. Aina, O.I. 2002. "Technological Assimilation in Small Enterprises Owned by Women in Nigeria". *Technology Policy and Practice in Africa*. Longman: London, UK.
2. Asiedu, J.J. 1989. *Processing of Tropical Crops*. Macmillan Publ.: London, UK.
3. FAO. 2004. "Small Scale Palm Oil Processing in Africa". *FAO Agricultural Service Bulletin*.148.
4. USDA. 2007. "Indonesia: Palm Oil Production Prospects Continue to Grow. USDA-FAS, Office of Global Analysis: Washington, D.C.
5. Ilori, S.A., I.U. Jahun, and B.A. Omeni. 1997. *Exam Focus Mathematics for WASSCE and SSCE*. University Press, PLC.: Ibadan, Nigeria. 89.
6. Jekayinfa, S.O. and A.I. Bamgboye. 2004. "Energy Requirements for Palm Kernel Oil Processing Operations". *Nutrition & Food Science*. 34(4): 166–173.
7. Kheiri, M.S.A. 1985. "Present and Prospective Development in the Palm Oil Processing Industry". *Journal of American Oil Chemists Society*. 2:210–219.
8. Khurmi, R.S. 2008. *Strength of Materials*. McGraw-Hill, S. Chand & Company Ltd.: New Delhi, India.
9. Khurmi R.S. and J.K. Gupta. 2006. *A Textbook of Machine Design, First Multicolor Edition*. Eurasia Publishing House: New Delhi. 509-556.
10. Kurki, A., J. Bachmann, and H. Hill. 2004. "Oil Seed Processing for Small–Scale Producers". NCAT Agriculture Specialist USA. Available at: [www.attra.ncat.org/attra-pub/oilseed.html](http://www.attra.ncat.org/attra-pub/oilseed.html)
11. Malaysian Palm Oil Industry Performance. 2009. *Global Oils & Fats Business Magazine*. 6(1).
12. Olajide, J.O. and O.J. Oyelade. 2002. "Performance Evaluation of the Strategic Grain Reserve Storage Programme (SGRSP) in Nigeria". *Technovation*. 22:463–468.
13. Omuta, G.E.D. and A.G. Onorkahrage. 1997. *Regional Dev. and Planning for Africa*. McMillan Press: University of Benin: Benin, Nigeria.
14. Gupta, S.K. (ed.). 2012. *Technological Innovations in Major World Oil Crops*. Volume 1:165-20 [http://rd.springer.com/chapter/10.1007/978-1-4614-0356-2\\_7](http://rd.springer.com/chapter/10.1007/978-1-4614-0356-2_7).

## SUGGESTED CITATION

Azodo, P.A., A.B. Hassan, J. Ezenwa, and P.U. Ogban. 2013. "Design and Fabrication of Motorized Hydraulically Operated Palm Oil Press". *Pacific Journal of Science and Technology*. 14(1):79-88.

 [Pacific Journal of Science and Technology](http://www.akamaiuniversity.us/PJST.htm)